

DUSCHRINNE R2

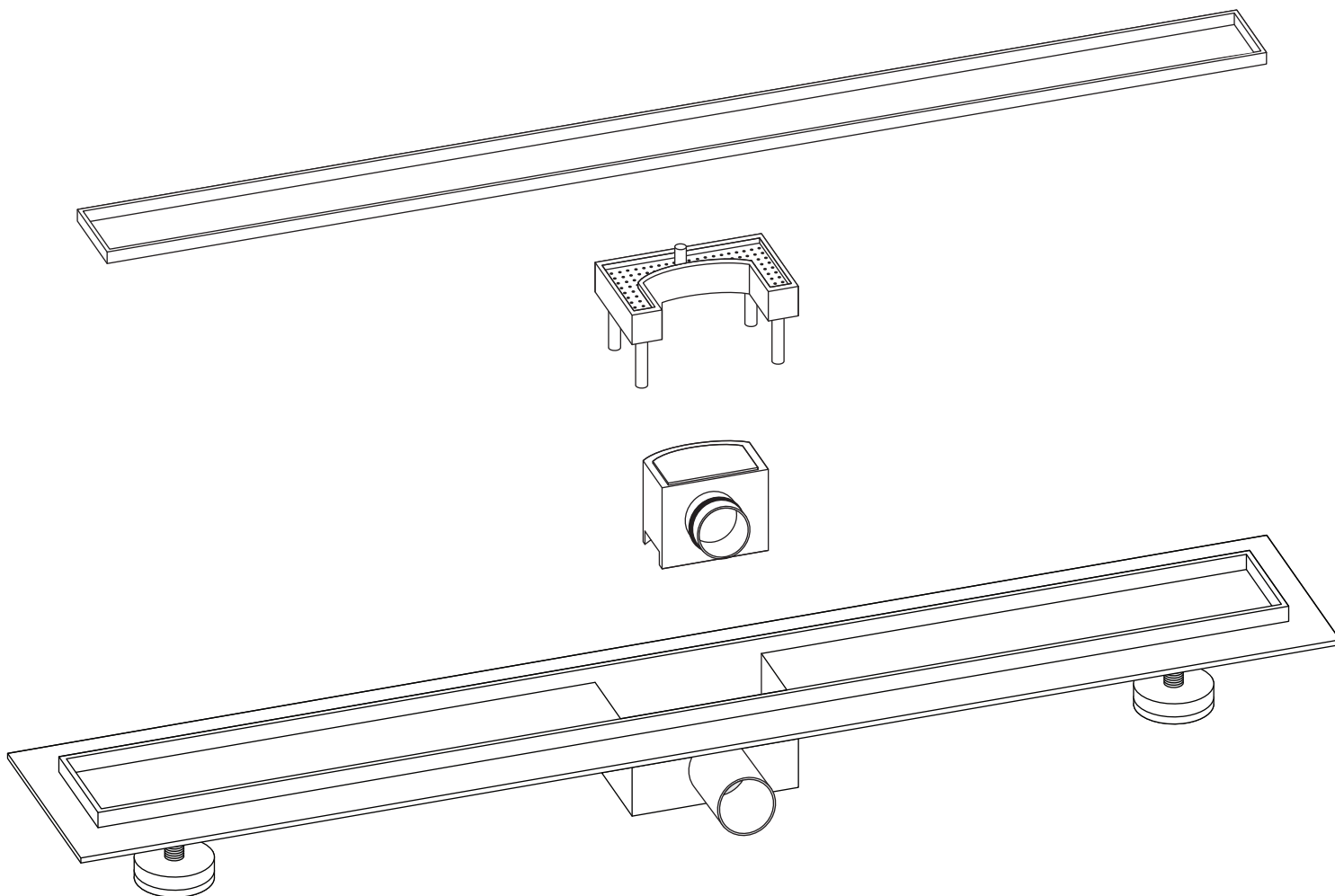

DE

Diese Aufbauanleitung wurde von uns selbst erstellt. Es handelt sich dabei um eine Aufbauempfehlung. Ersuchen Sie unbedingt einen Fachmann, welcher Ihnen Ihre Montage und sonstige Details nachweislich bestätigt/abnimmt! Wir empfehlen den Aufbau durch einen Fachmann, welcher Ihnen eine Rechnung ausstellt – damit Sie eine Garantie auf Dichtigkeit etc. erhalten. Wasserschäden oder Verletzungen werden somit vermieden – nur so sichern Sie sich ab. Wir haften nicht für Ihren Aufbau, jedoch stehen wir Ihnen für weitere Rückfragen gerne zur Verfügung.

t.: 040/73675470
e-mail: service@i-flair.de

EN

These assembly instructions were created by ourselves. It is a construction recommendation. It is imperative that you ask an expert who will verifiably confirm/accept your assembly and other details! We recommend assembly by a specialist, who will issue an invoice to you - so that you receive a guarantee on tightness, etc.. Water damage or injuries are thus avoided - this is the only way to protect yourself. We are not liable for your construction, but we will be gladly available for any queries and further information.

t.: 040/73675470
e-mail: service@i-flair.de

ES

Recomendaciones de montaje – a leer atentamente antes de la instalación. La instalación debe ser realizada por un profesional del sector de los sanitarios. Además, el profesional que intervendrá en la instalación deberá garantizarle una perfecta impermeabilización etc. De este modo se evitan lesiones o danos por agua. Si tiene alguna pregunta con respecto a las instrucciones de montaje, quedamos a su disposición.

t.: 040/73675470
e-mail: service@i-flair.de

FR

Recommandations de montage - à lire obligatoirement avant installation. Notre société décline toute responsabilité et se réserve le droit de ne pas assurer sa garantie dans le cas où ce produit ne serait pas installé par du personnel qualifié. Par ailleurs, le professionnel qui interviendra devra également vous garantir sa parfaite étanchéité etc. Les dégâts d'eau ou tout risque de blessure sont ainsi évités. Si vous avez des questions relatives aux instructions de montage, nous restons à votre entière disposition.

t.: 040/73675470
e-mail: service@i-flair.de

PT

Recomendações de montagem – ler atentamente antes da instalação. A instalação deve de ser efectuada por um profissional especializado na instalação de equipamento de sanitários. A nossa empresa declina toda e qualquer responsabilidade reservando-se o direito de não assegurar a garantia, caso o artigo não seja instalado por pessoas qualificadas (sendo a factura da instalação uma prova). O profissional que irá intervir na instalação deste artigo, terá que lhe garantir a perfeita impermeabilização. Deste modo, evitam-se danos causados pela água ou ferimentos. Se tiver alguma dúvida sobre as instruções de montagem, não hesite em nos contactar.

t.: 040/73675470
e-mail: service@i-flair.de

MODELLE | MODELS | MODELOS | MODÈLES | MODELOS

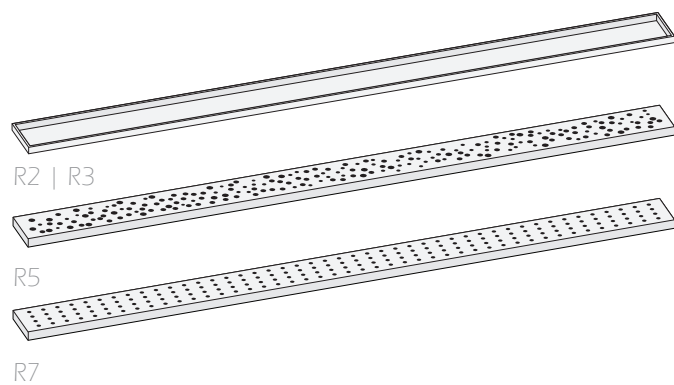
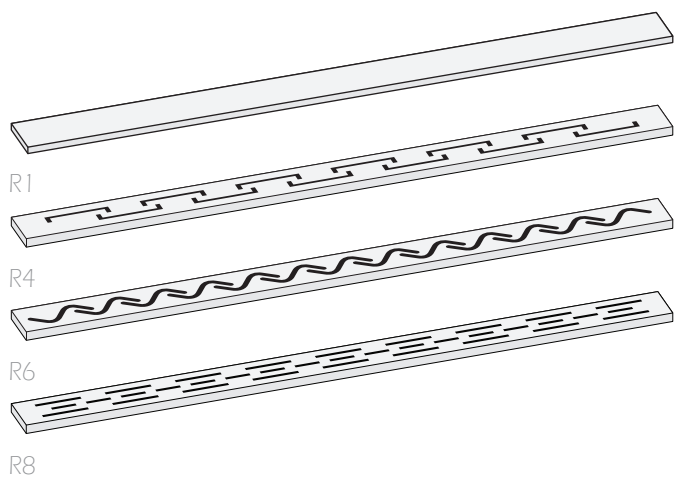

TEILEAUFLISTUNG | PARTS LIST | LISTA DE PIEZAS | LISTE DES PIÈCES | LISTA DE PEÇAS

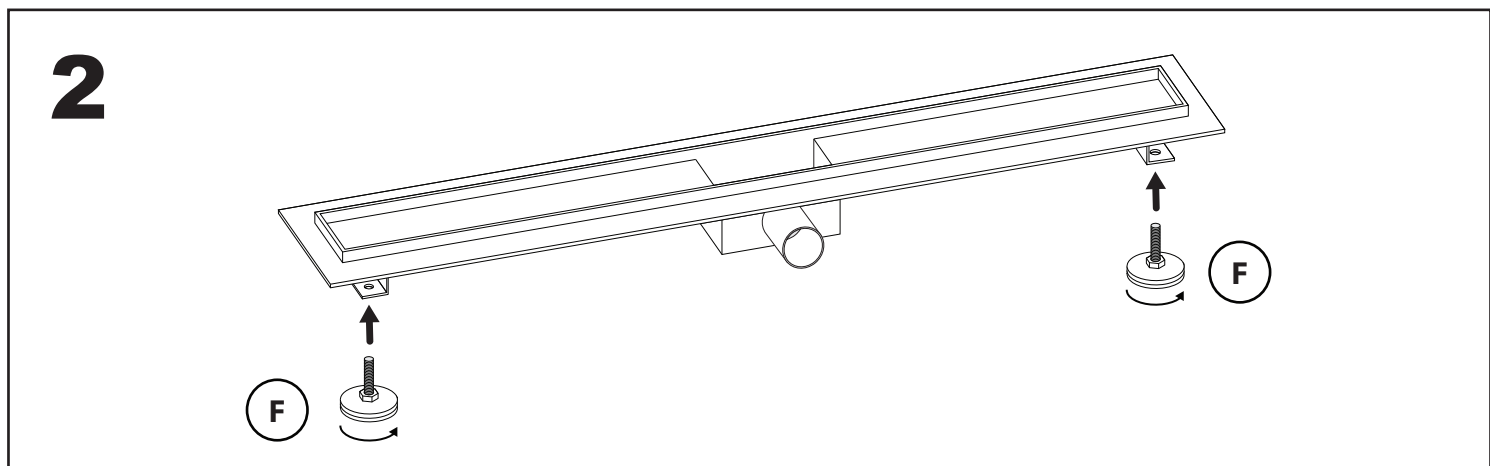
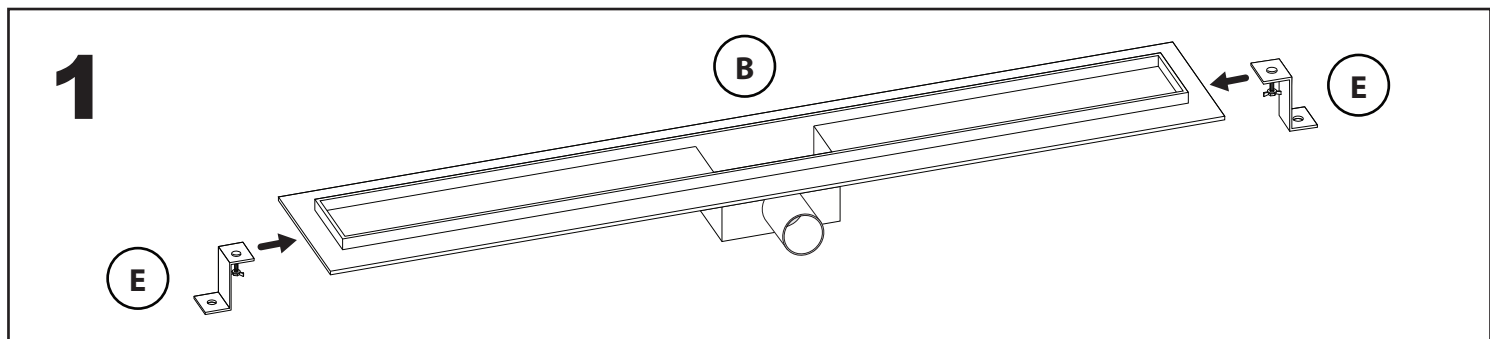
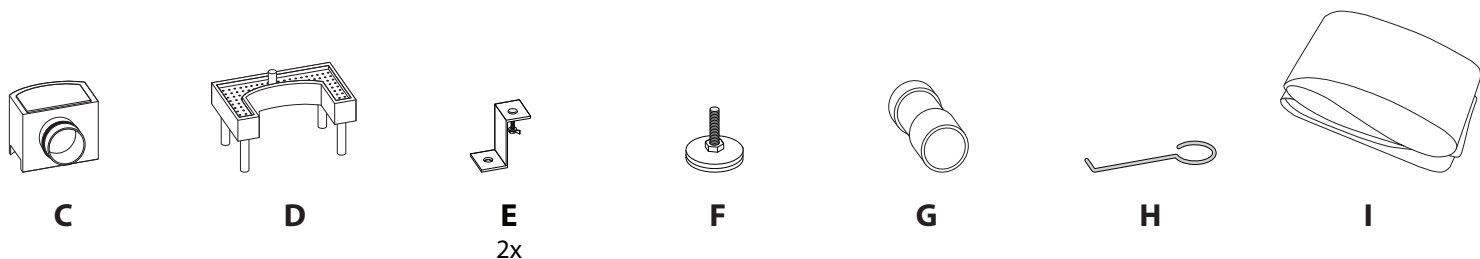
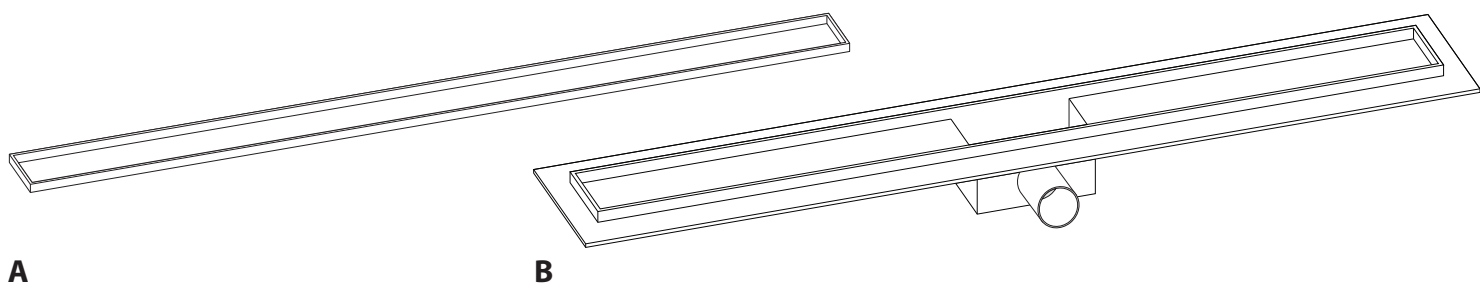

3

AUSRICHTEN | LEVEL | NIVELAR | ÉGALISER | NIVELAR

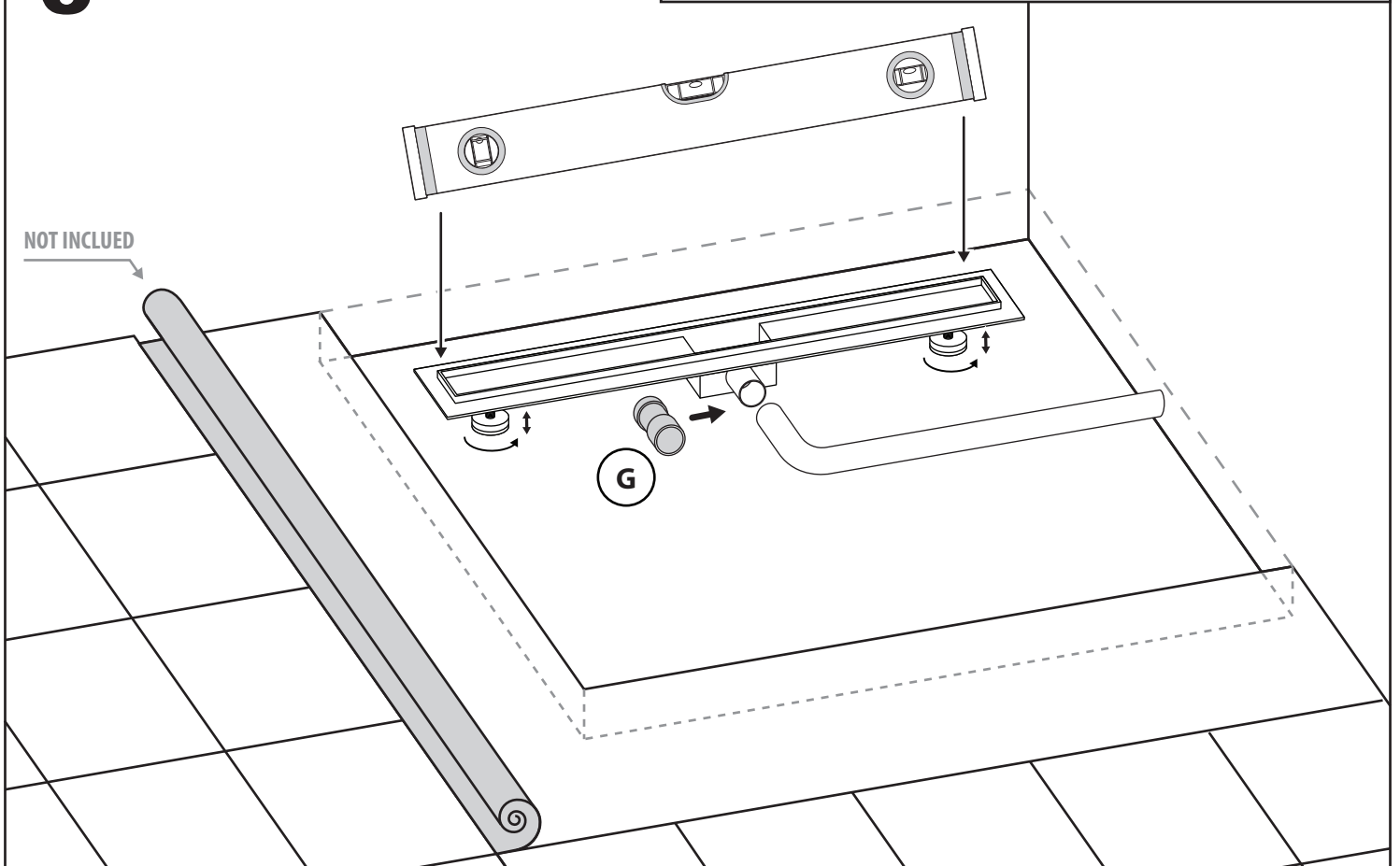

4

ZEMENTIEREN | CEMENT | CIMENTAR | CIMENTER | ACIMENTAR

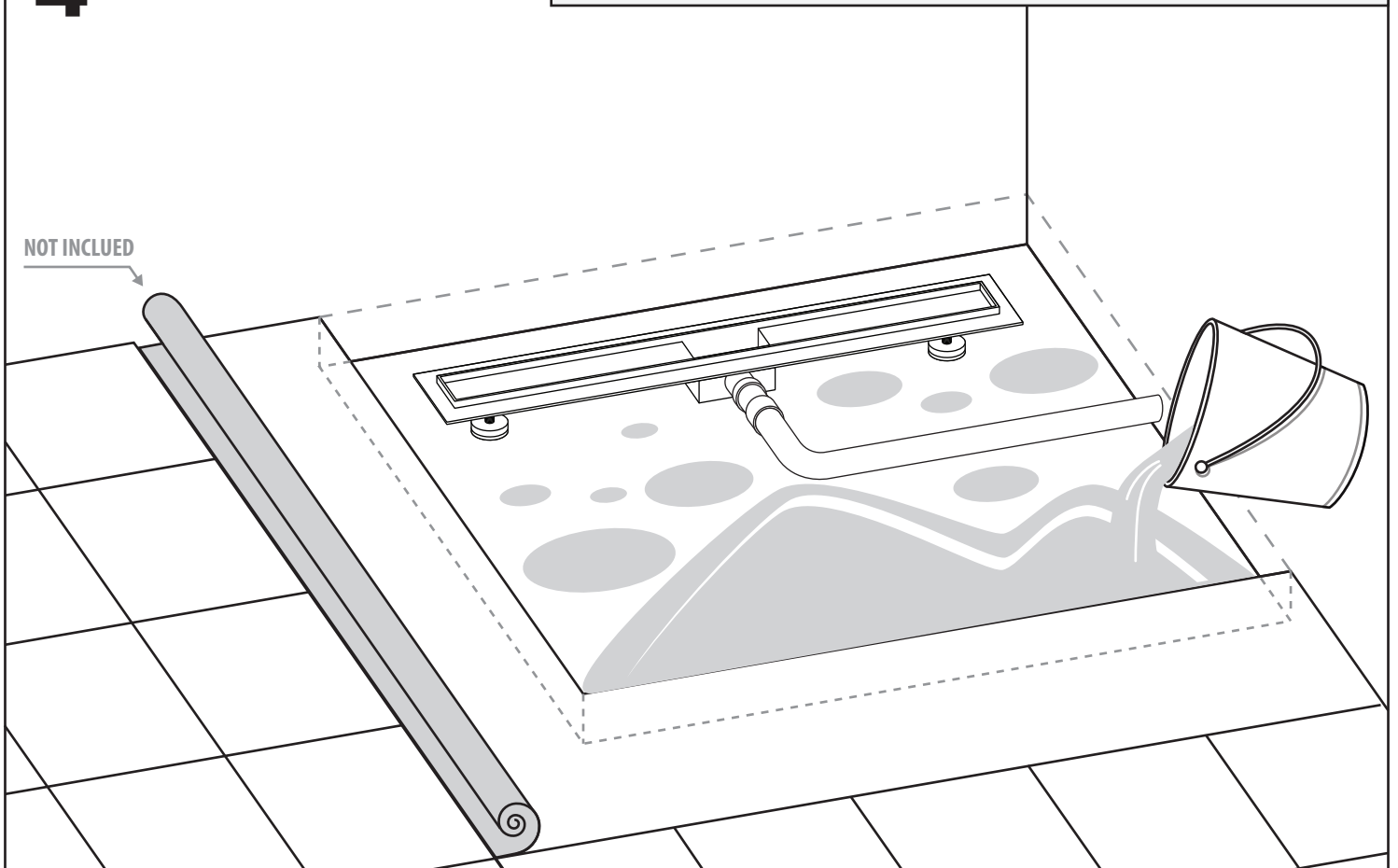

5

**ESTRICHGEFÄLLE | LEVELING DRAIN ANGLE | NIVELAR ÁNGULO DE FLUJO
ÉGALISER L'ANGLE D'ÉCOULEMENT | NIVELAR ÂNGULO DE ESCOAMENTO**

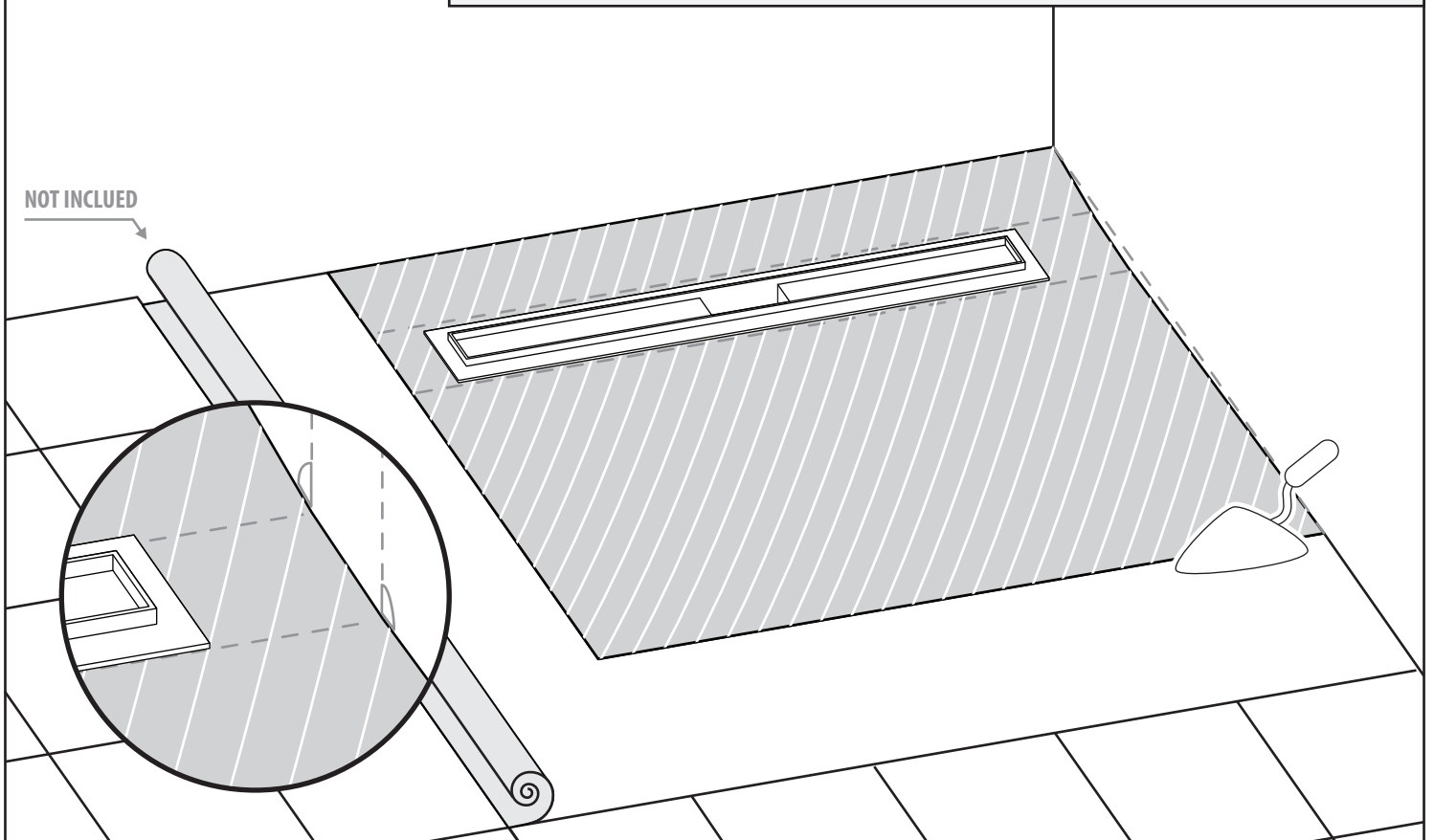

6

DICHTMATTE EINSETZEN | SCREEN PASTE | PEGAR LONA | COLLIER EN TOILE | COLAR TELA

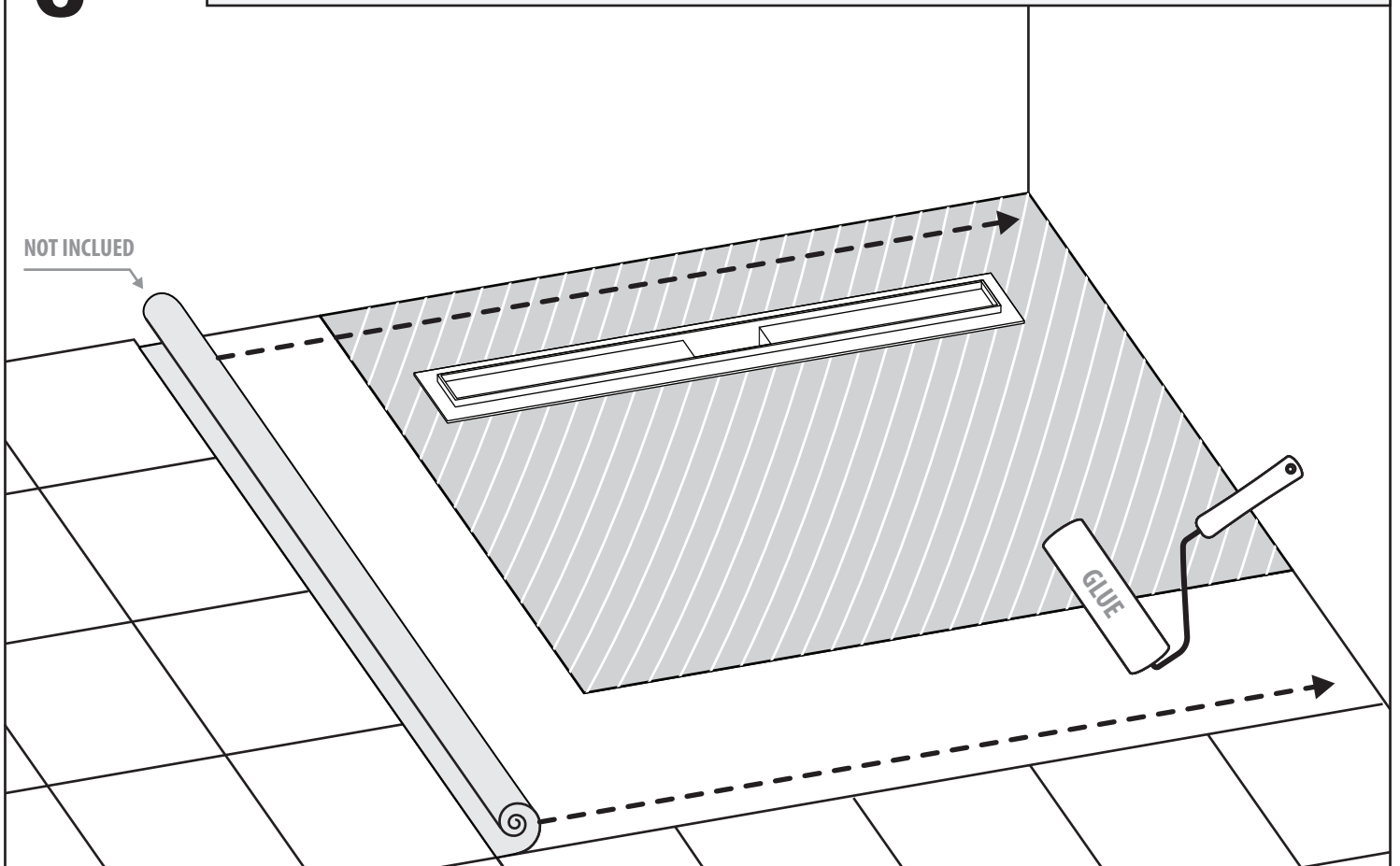

7

AUSSCHNEIDEN | CUT SCREEN | CORTAR LONA | TOILE COUPÉE | COLAR TELA

NOT INCLUDED

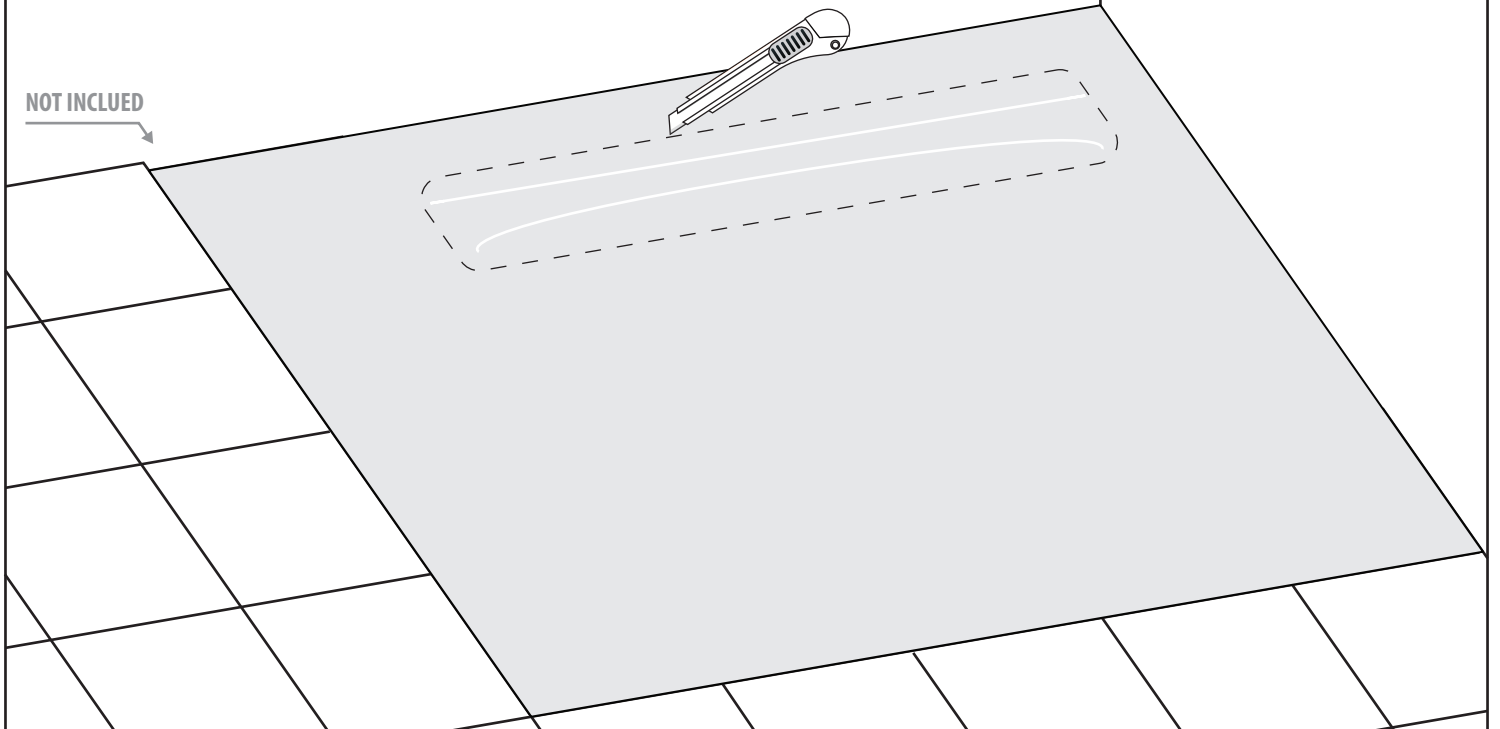

8

SCHLEIFEN UND REINIGEN | SAND AND CLEAN | LIJAR Y LIMPIAR
PONÇAGE ET NETTOYAGE | LIXAR E LIMPAR

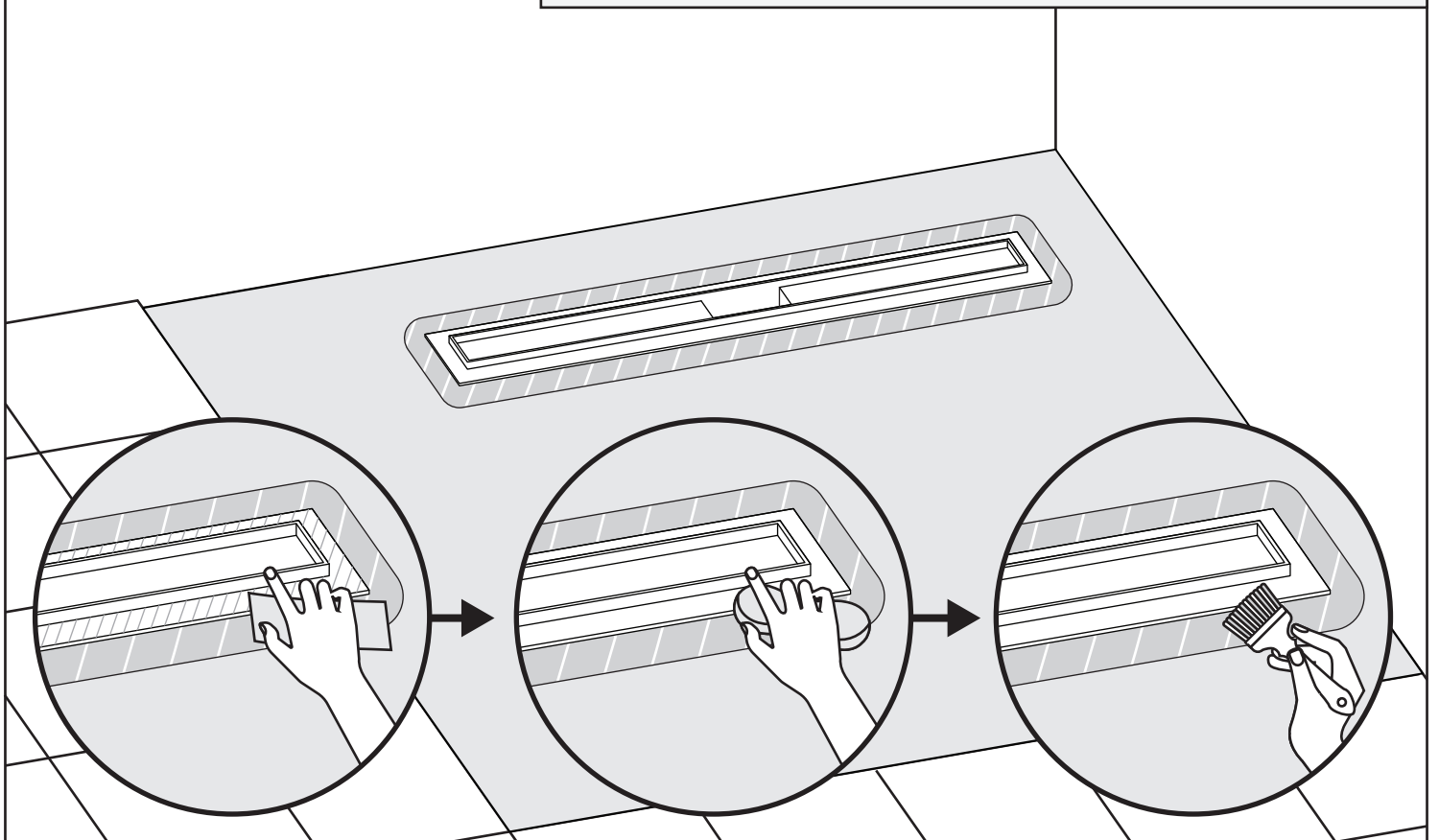

9

FLIES KLEBEN | PASTE | PEGAR | COLLIER | COLAR

1

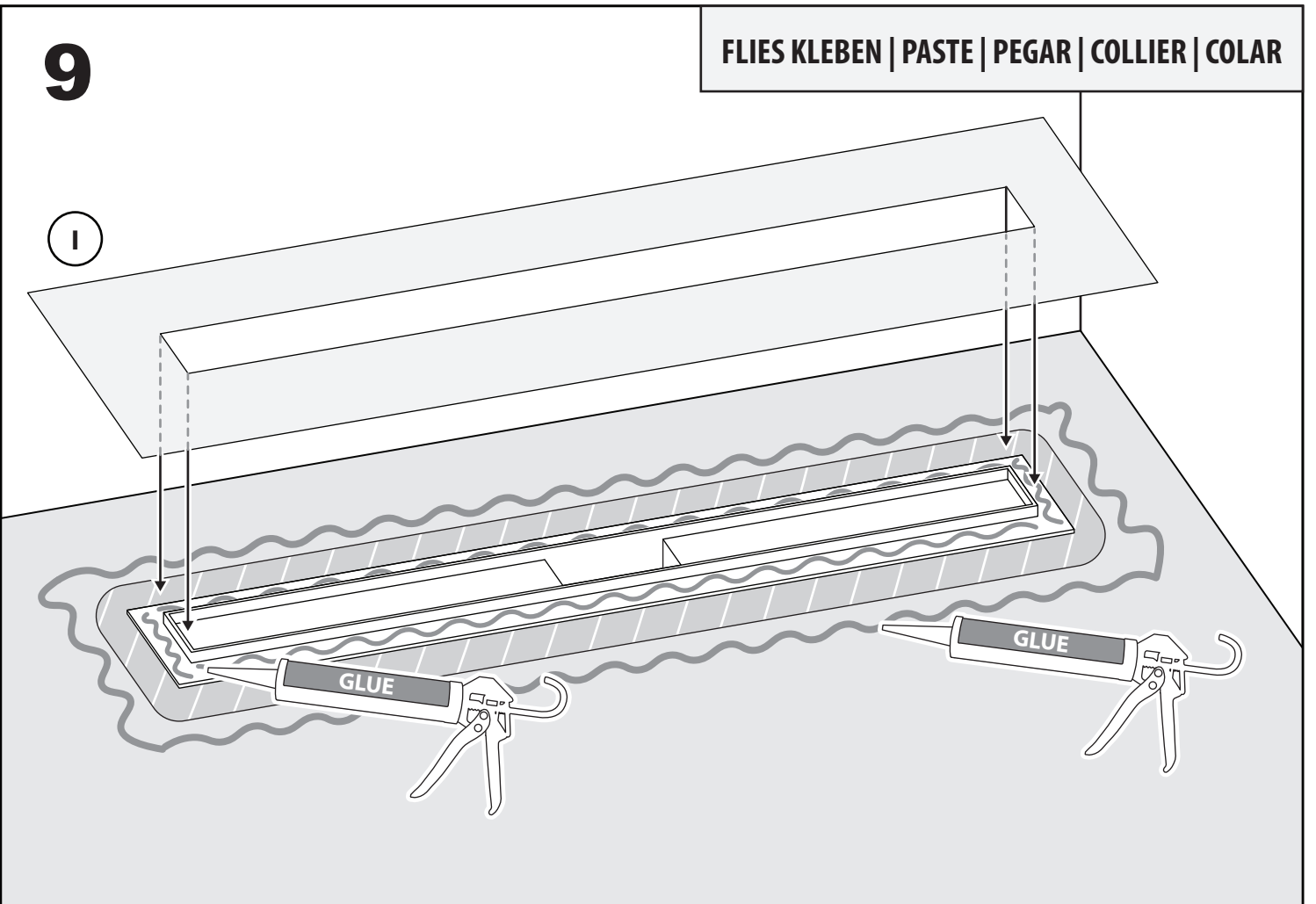

10

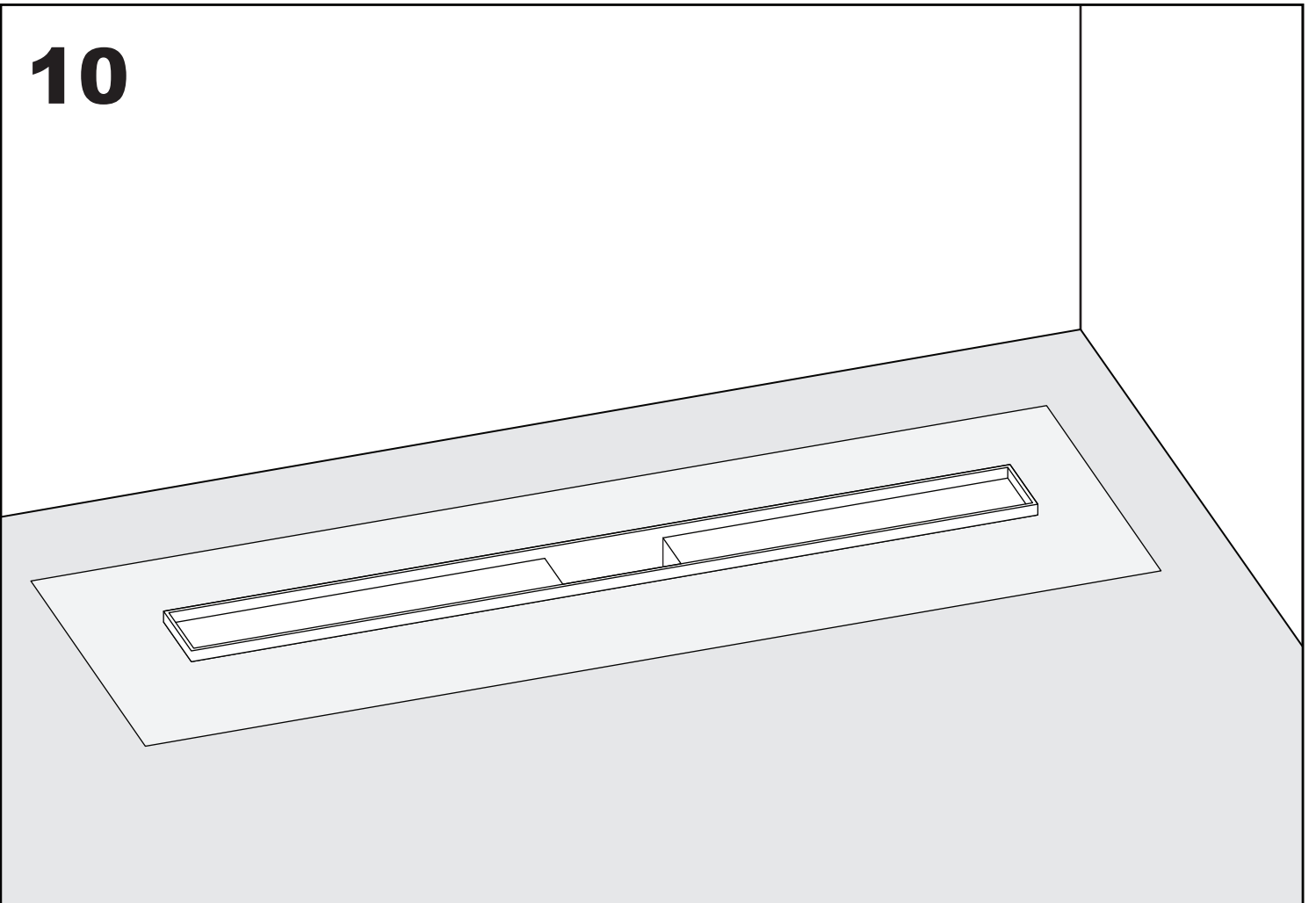

11

BEFLIESEN | TILE | BALDOSAS | CARREAU TILE | ASSENTAR AZULEJO

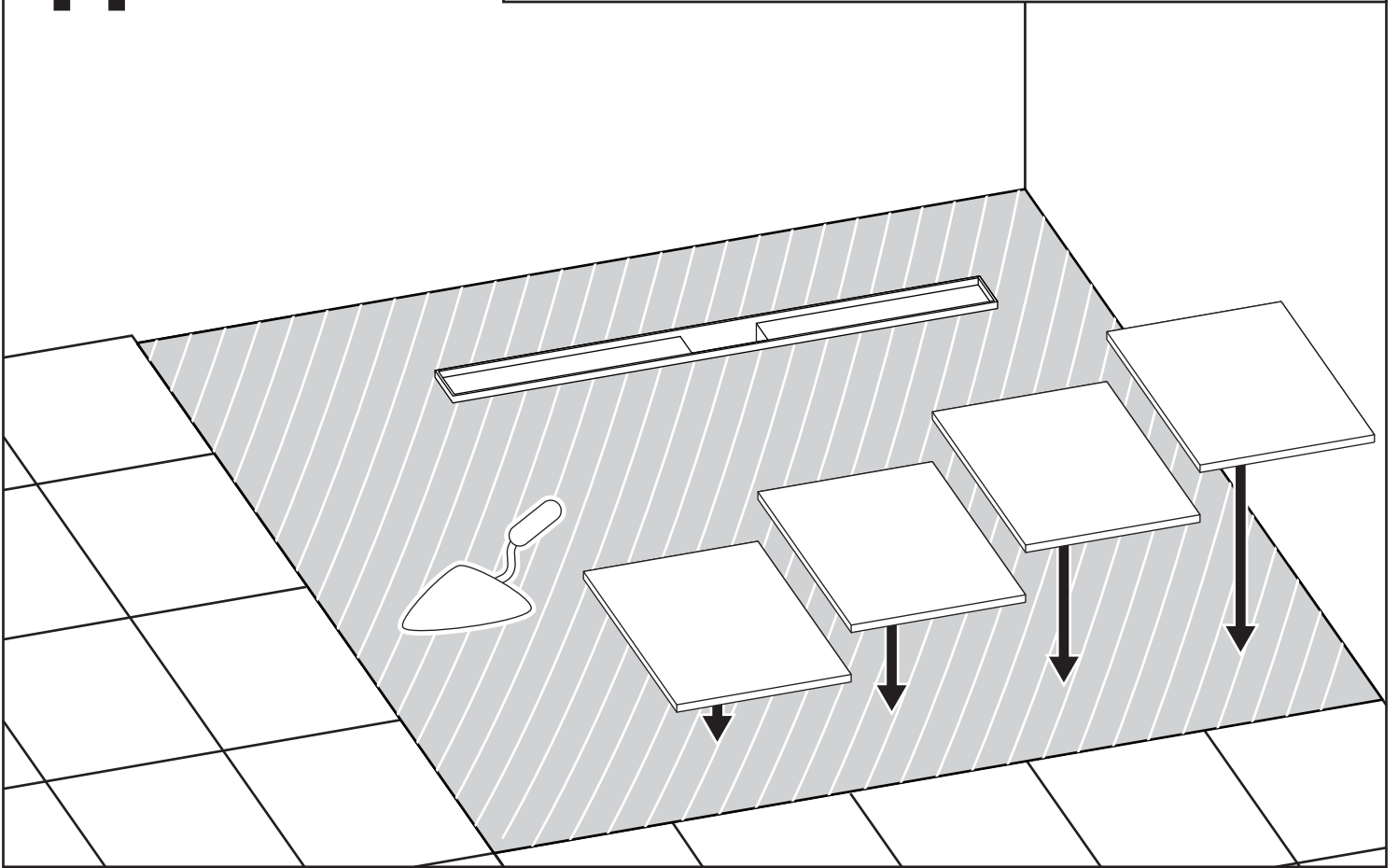

12

FLIESEN SCHNEIDEN UND EINKLEBEN | CUT TILE | CORTAR BALDOSAS
COUPER CARREAU | CORTAR AZULEJO

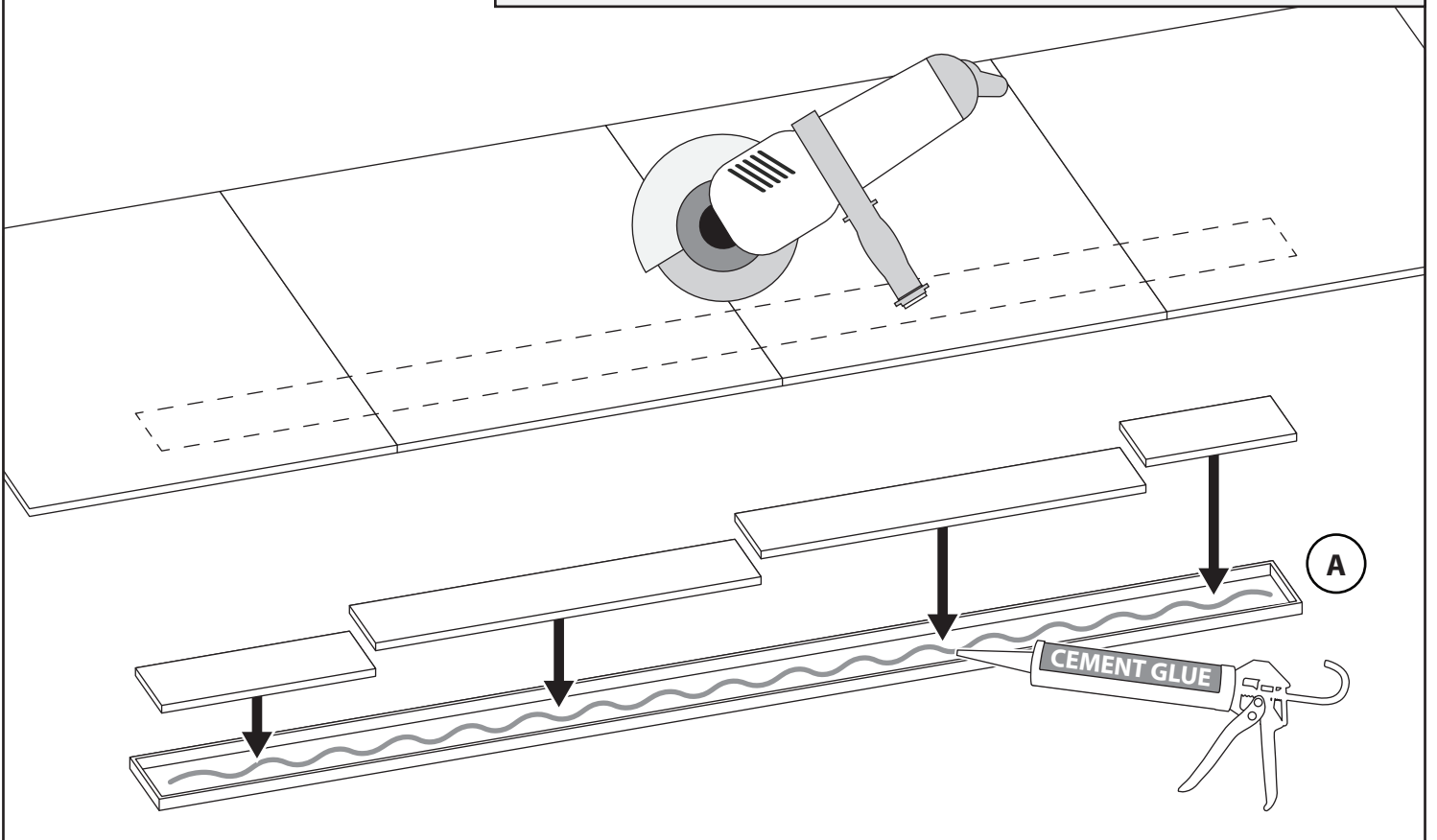

13

